

Standard Dual Sided Banner Stands

STAND 800D STAND 920D



The Orient is a simplistic and elegantly designed banner stand that has the capability to be double sided. Dual retractor mechanisms allow you to present two graphics back to back. It is finished in anodized silver with heavy duty molded endplates. Padded carry bag is included.



features and benefits:

- Available in two widths
- Variable graphic height: 60" - 83.25"
- Anodized silver base
- Hybrid bungee/ telescoping pole with toolless quick rail
- Adjustable feet on base
- Molded end caps
- Supplied with a padded carry bag with strap
- Lifetime limited warranty against all manufacturers defects

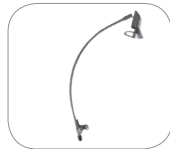
dimensions:

Hardware	Shipping
<p>Assembled unit:</p> <p>800mm: 32.68"w x 84.75"h x 7.28"d 830mm(w) x 2153(h) x 185mm(d)</p> <p>920mm: 37.49"w x 84.75"h x 7.28"d 950mm(w) x 2153mm(h) x 185mm(d)</p> <p>Base dimensions:</p> <p>800mm: 32.68"w x 3.15"h x 7.28"d 830mm(w) x 80mm(h) x 185mm(d)</p> <p>920mm: 37.49"w x 3.15"h x 7.28"d 950mm(w) x 80mm(h) x 185mm(d)</p>	<p>Shipping dimensions - ships in one box</p> <p>800mm: 37"l x 10"h x 5"d 940mm(l) x 254mm(h) x 127mm(d)</p> <p>920mm: 39"l x 12"h x 6"d 991mm(l) x 305mm(h) x 154.4mm(d)</p> <p>Approximate shipping weight (w/o graphic):</p> <p>800mm: 13 lbs / 5.90 kgs</p> <p>920mm: 15 lbs / 6.8 kgs</p>
Graphic	additional information:
<p>Refer to related graphic template for more information.</p> <p>WARNING: Always attach graphic to base and top rail before removing the locking pin. After fitting, the graphic should be left for 24 hours before use to ensure the adhesive bonds sufficiently. Opening the base will invalidate the product warranty.</p>	<p>Graphic materials: anti-curl vinyl, premium opaque fabric, melinex</p> <p>Lumina 2 and LED Spot banner lighting option available</p> <div style="display: flex; justify-content: space-around; align-items: center;"> <div style="text-align: center;">  <p>Lumina 2</p> </div> <div style="text-align: center;">  <p>LED Spot</p> </div> </div>

We are continually improving and modifying our product range and reserve the right to vary the specifications without prior notice. All dimensions and weights quoted are approximate and we accept no responsibility for variance. E&OE. See Graphic Templates for graphic bleed specifications.

Set-up

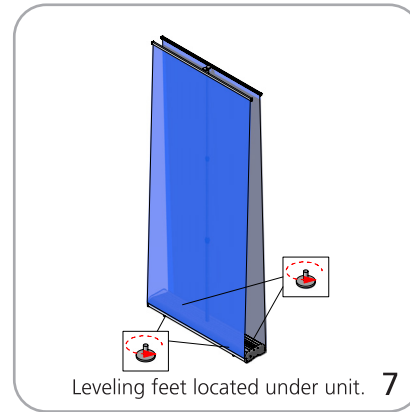
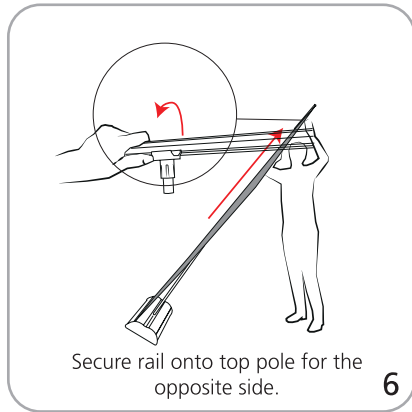
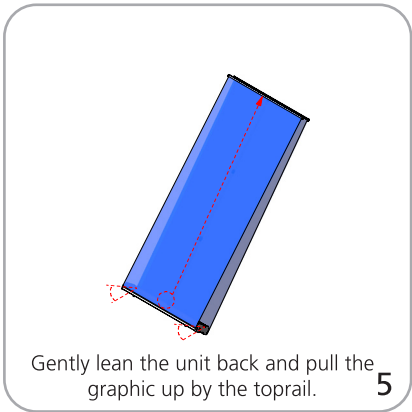
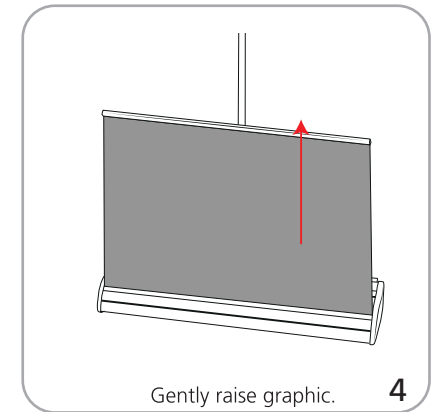
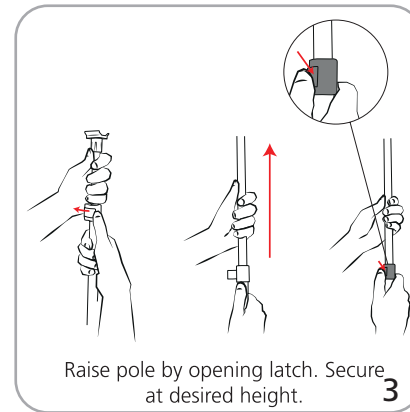
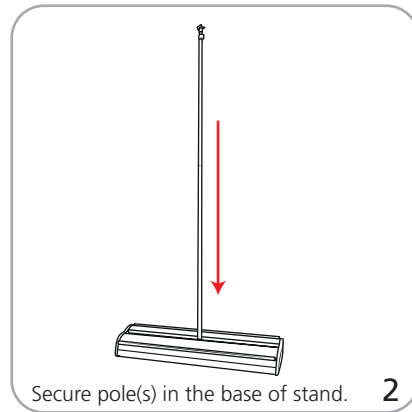
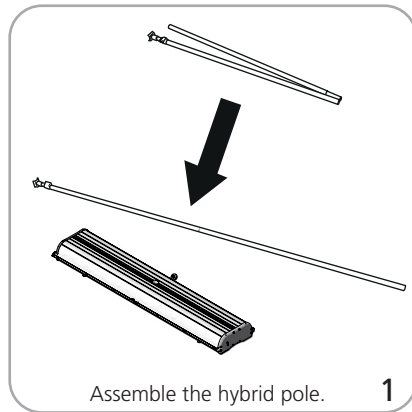

Graphic to top rail attachment

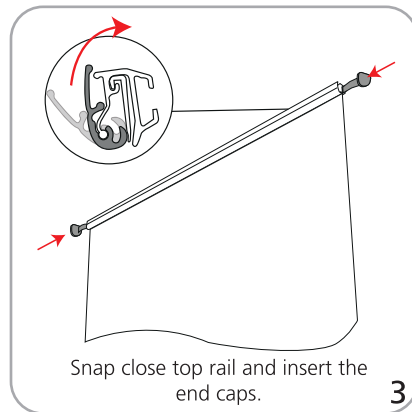
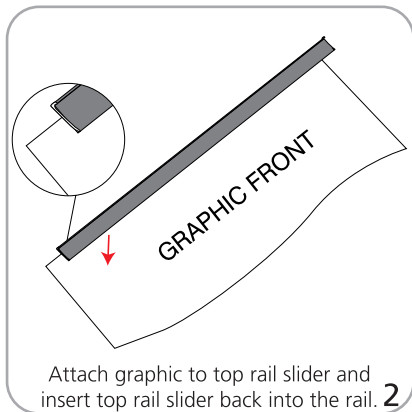
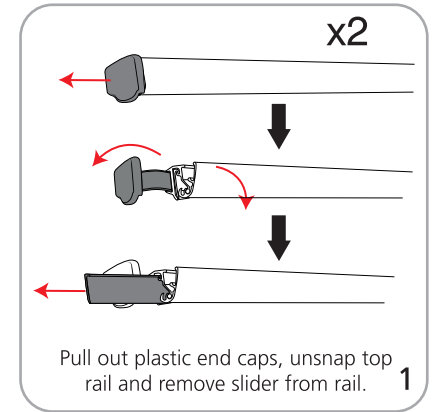

Graphic to base attachment

